



## Fireray® 50R/100R

### Anti-Condensation Heater

The Fireray® 50R/100R Anti-Condensation Heater has been designed to be used in environmental conditions where condensation affects the operation of optical beam smoke detectors.

Condensation occurs when the surrounding air is at a higher temperature than the surface that it comes in contact with. As air contains water, in the form of vapour, this will deposit on the cooler surface thus forming condensation.

The design of the Fireray® Anti-Condensation Heater utilises forced air, which results in a circulating current of warm air maintaining the detector lens at an incrementally higher temperature than the surrounding air. The heater will reduce the likelihood of condensation forming on the lens which, in turn, reduces the potential for false alarms.

#### Features

- Bespoke bracket to ensure optimum performance of heater
- Designed to prevent the build-up of condensation
- For use in temperature controlled storage areas and cold environments
- Reflective Prism Heater also available

#### Technical Specification

Operating voltage:	24 V AC/DC
Power consumption at 24V:	20 W
Maximum in-rush current:	3 A
Steady-state current at 24V:	0.8 A (Typical)
Operating temperature:	-10°C to +45°C
Recommended fuse rating:	T2A
Connections:	4 leads (2 for heater & 2 for fan)
Average temperature increase of lens above ambient:	10°C



Anti-Condensation Heater Bracket



Anti-Condensation Heater with Detector

Anti-Condensation Heater with Detector and Alignment Bracket

#### Dimensions

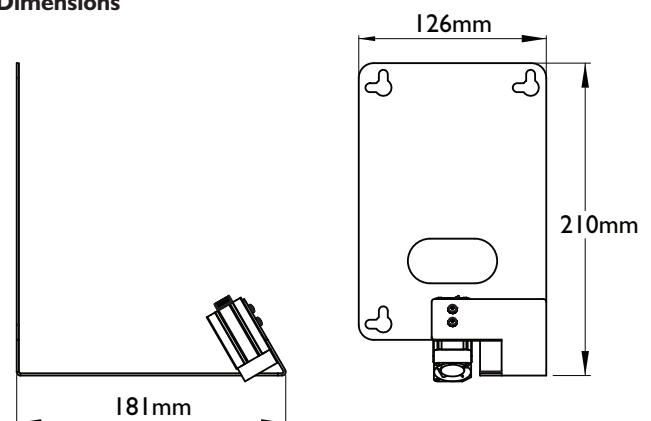

FFE Limited  
9 Hunting Gate, Hitchin  
Hertfordshire, SG4 0TJ UK

t +44 (0) 1462 444 740  
f +44 (0) 1462 444 789  
e sales@ffeuk.com  
w www.ffeuk.com

Formerly known as Fire Fighting Enterprises Ltd

Specifications and wiring information are provided for information only and are believed to be accurate. FFE Ltd assumes no responsibility for their use. Data and design are subject to change without notice. Installation and wiring instructions are shipped with the products and should always be used for actual installation. For more information, contact your Sales Representative.

Document Part No: 24-0093-02